



# Barceloneta

Cartagena de Indias

## Barceloneta

La Barceloneta es un SUB-Proyecto dentro del gran plan maestro de desarrollo de vivienda colectiva BARCELONA DE INDIAS, el se encuentra actualmente en construcción.

- 6 bloques de apartamentos de 4 pisos
- Playa privada de 3500 mts \*
- Piscina Oceánica de 3.500 m2 aprox
- Club House con areas sociales
- Gimnasio y zonas húmedas
- Parqueadero
- Zonas verdes
- Circuito peatonal
- Canchas de tennis
- Canchas de voley playa
- Canchas multiples
- Parque de cometas
- Putting green

Esta imagen es una representación y está sujeta a cambios.

4 \* Playa artificial en arena fina lavada de peña color crema. 5













Localización apartamentos pisos 1 al 3



Localización apartamentos altillo





Configuración planta tipo

APARTAMENTO A : 1 UND  
APARTAMENTO B : 1 UND  
APARTAMENTO C : 4 UND  
APARTAMENTO D : 2 UND  
APARTAMENTO E : 1 UND

TOTAL APARTAMENTOS POR PISO : 9

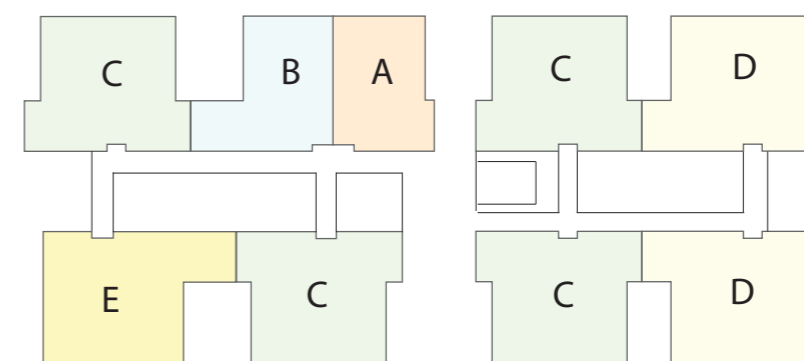

Planta pisos 1 al 3

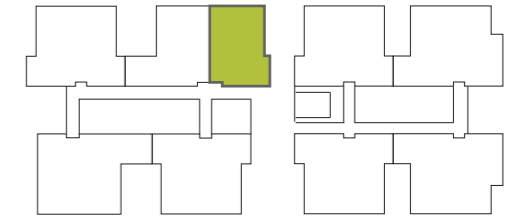
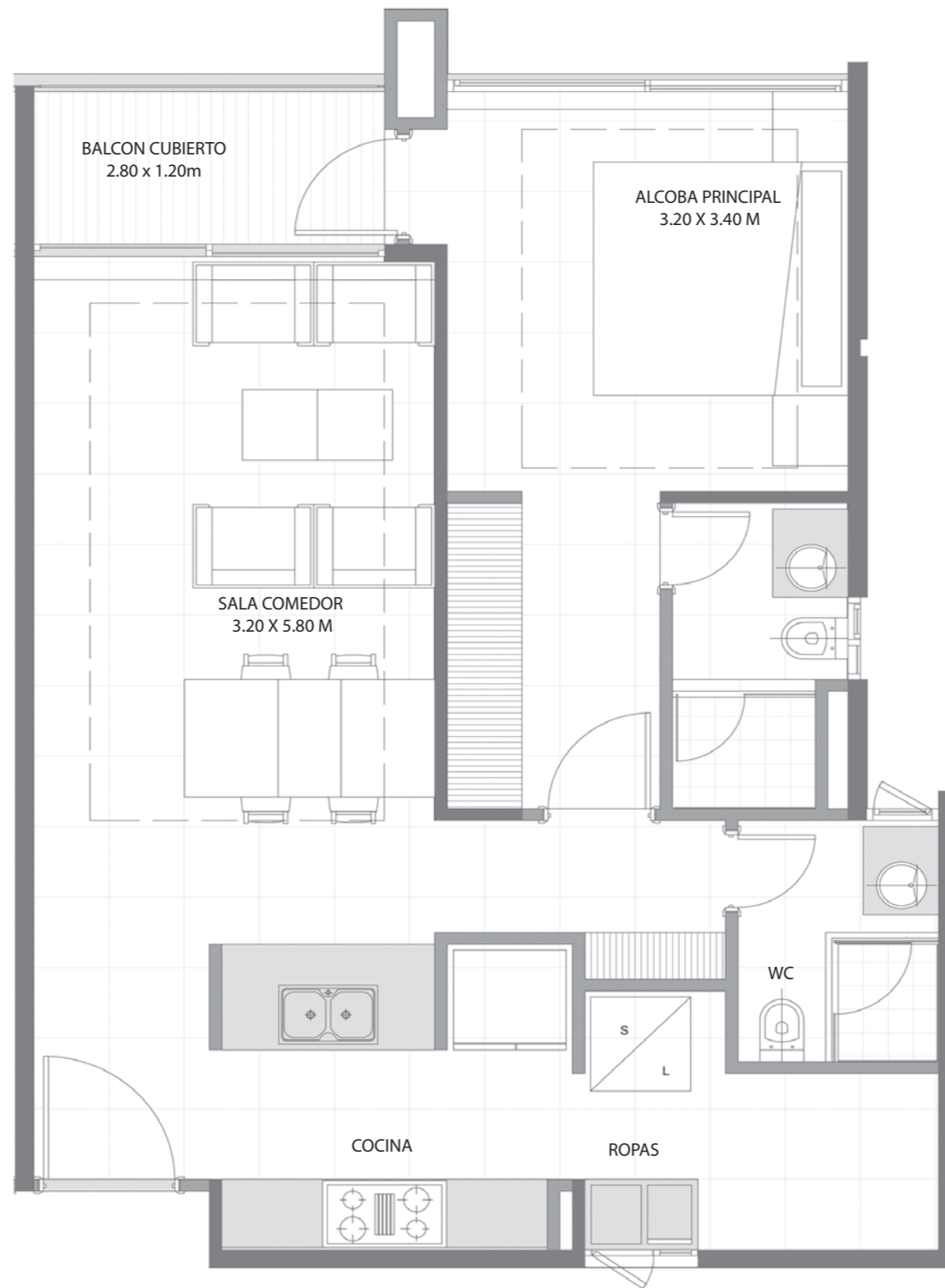

Apartamento Tipo A: 70M<sup>2</sup>

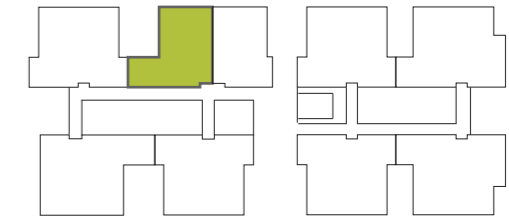

Apartamento Tipo B: 83M<sup>2</sup>

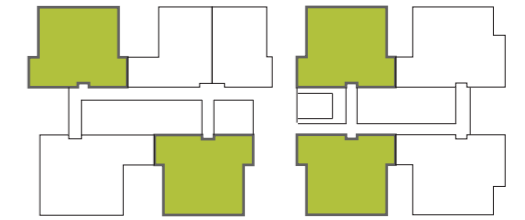

Apartamento Tipo C: 112M<sup>2</sup>

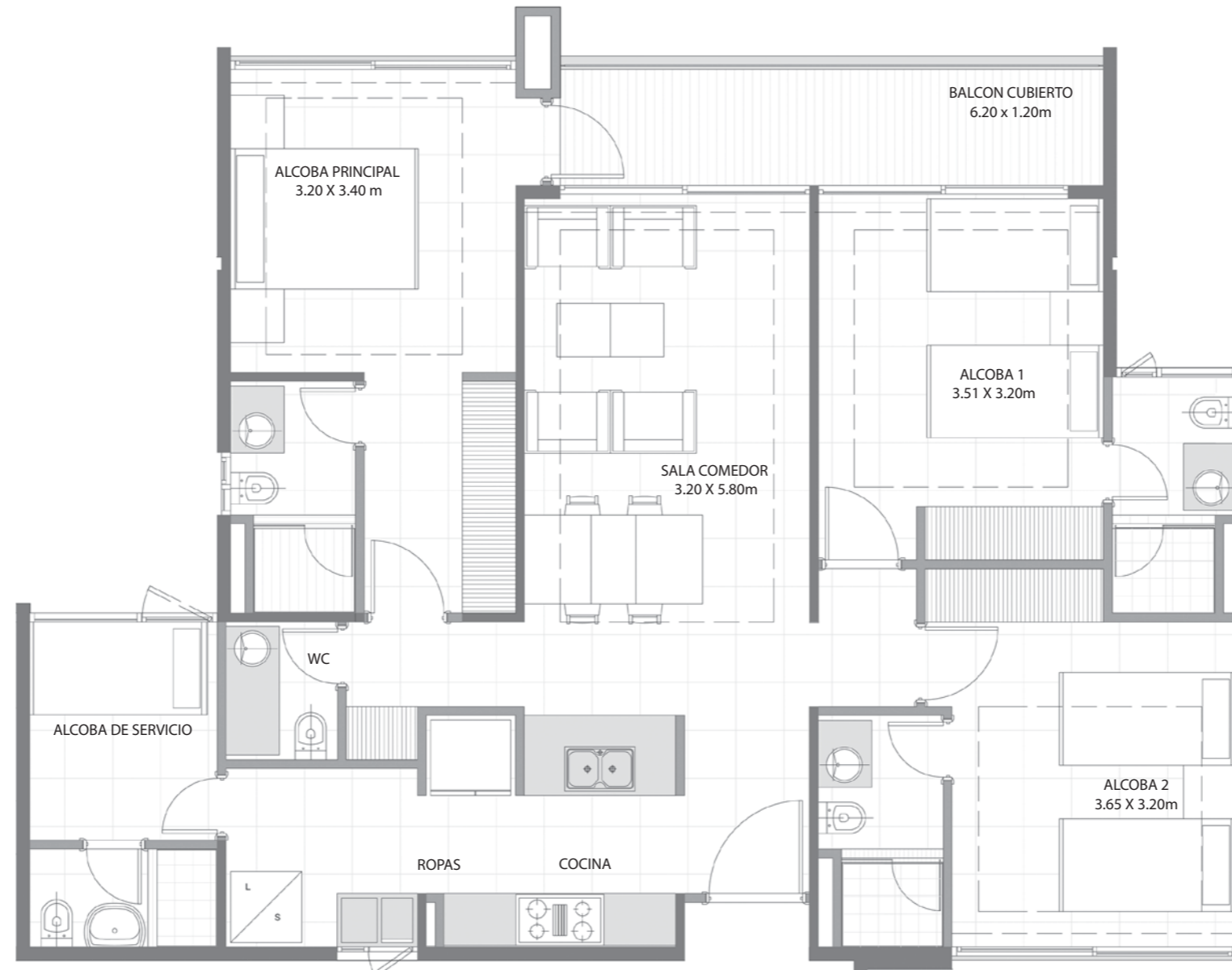
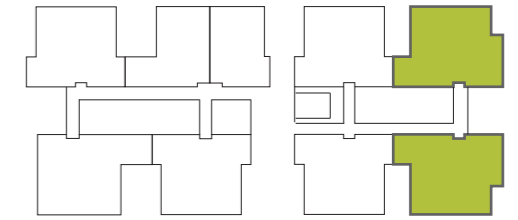

Apartamento Tipo D: 121M<sup>2</sup>

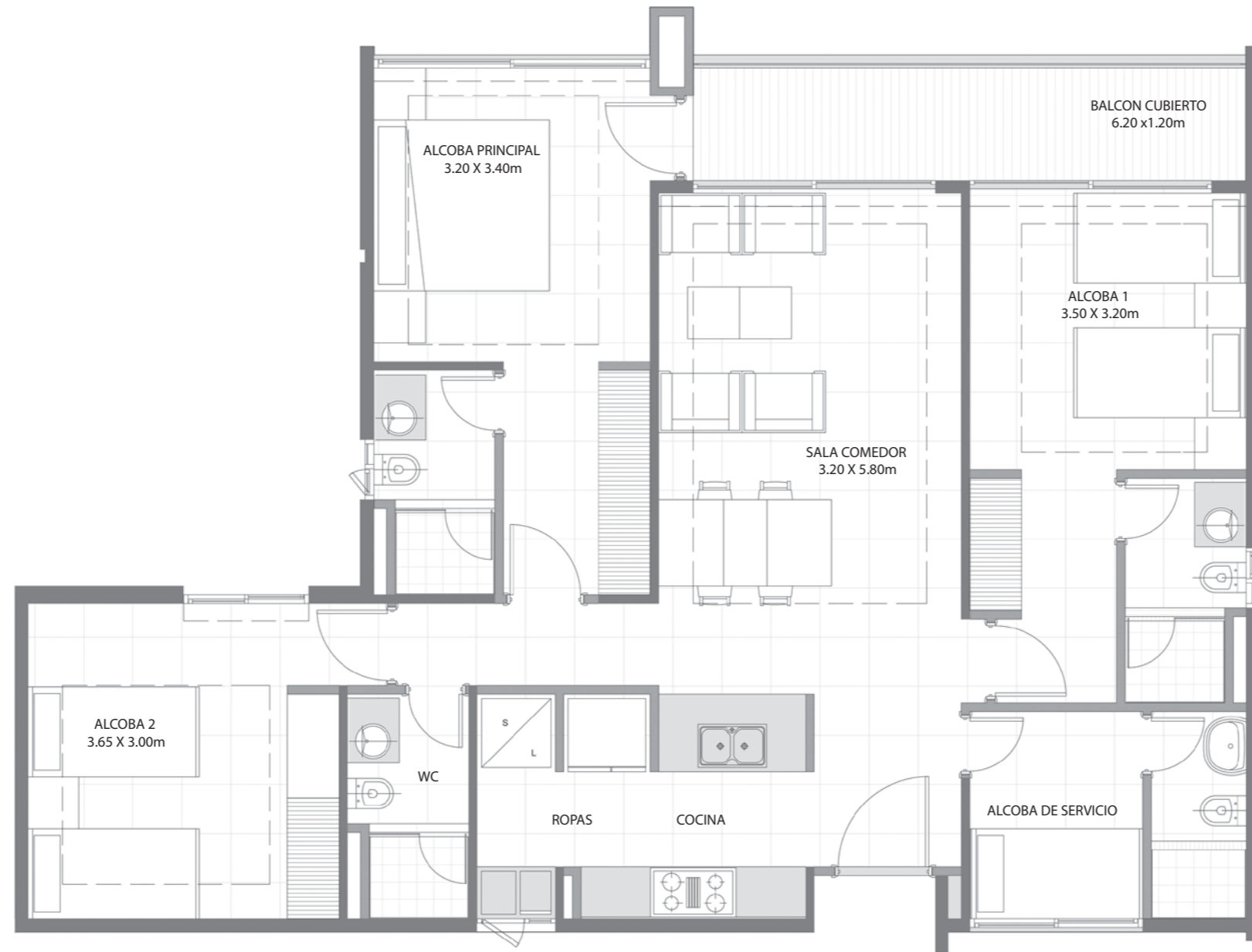
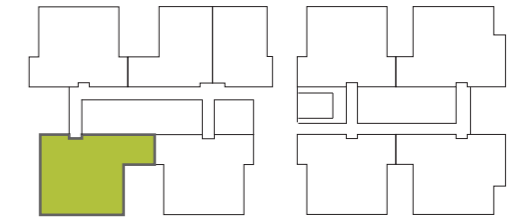

Apartamento Tipo E: 121M<sup>2</sup>

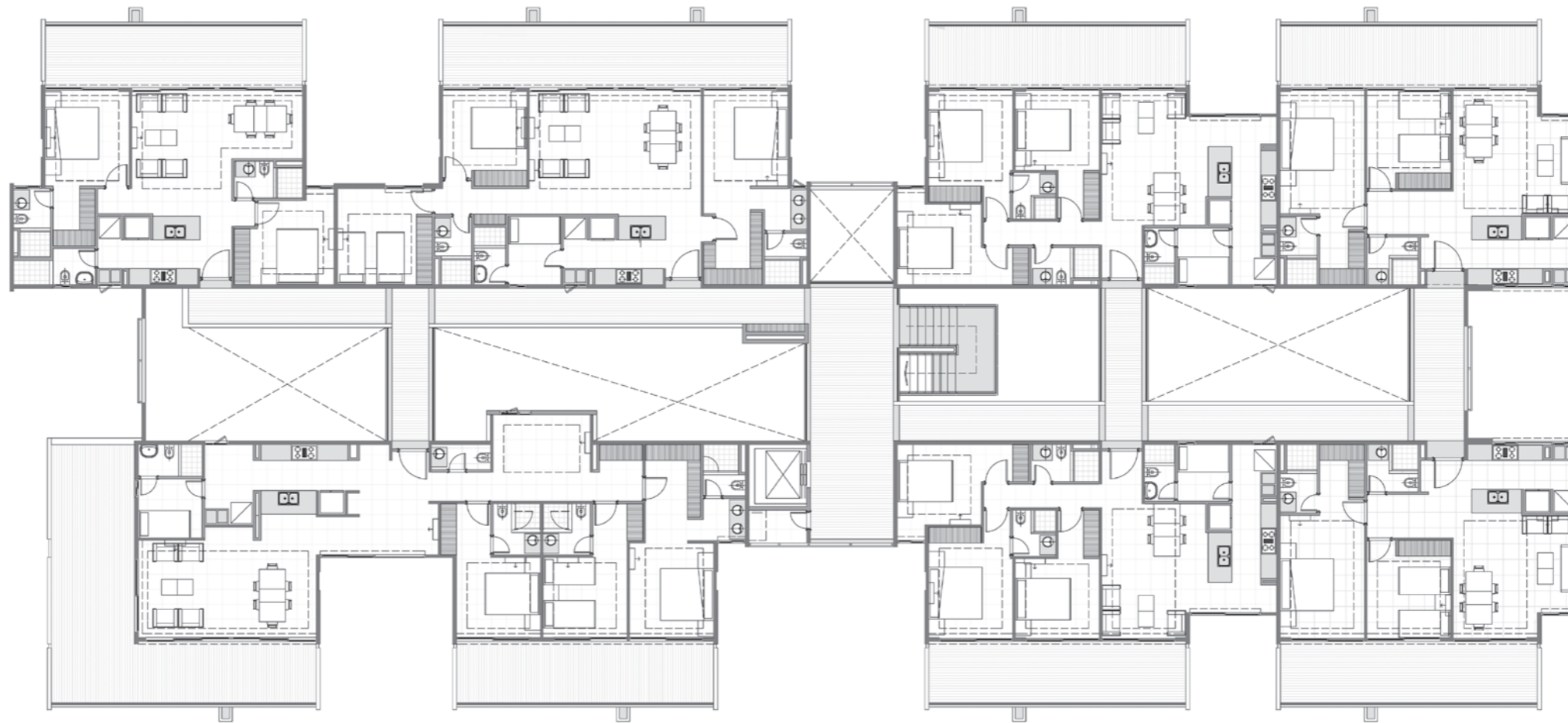

Configuración cuarto piso  
PENHOUSE 1 : 1 UND  
PENHOUSE 2 : 2 UND  
PENHOUSE 3 : 2 UND  
PENHOUSE 4 : 1 UND  
PENHOUSE 5 : 1 UND

TOTAL APARTAMENTOS  
CUARTO PISO: 7

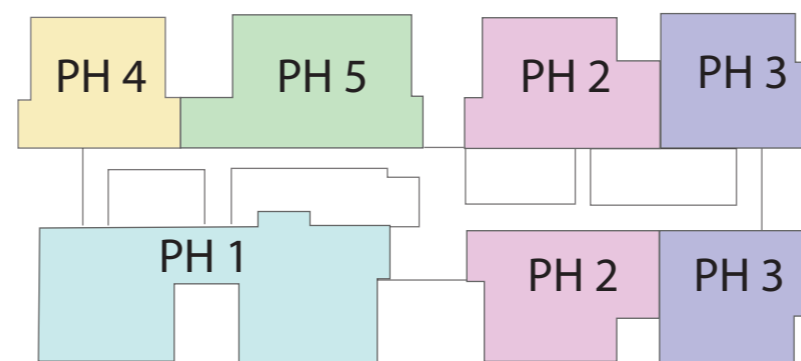

## Planta Altillo

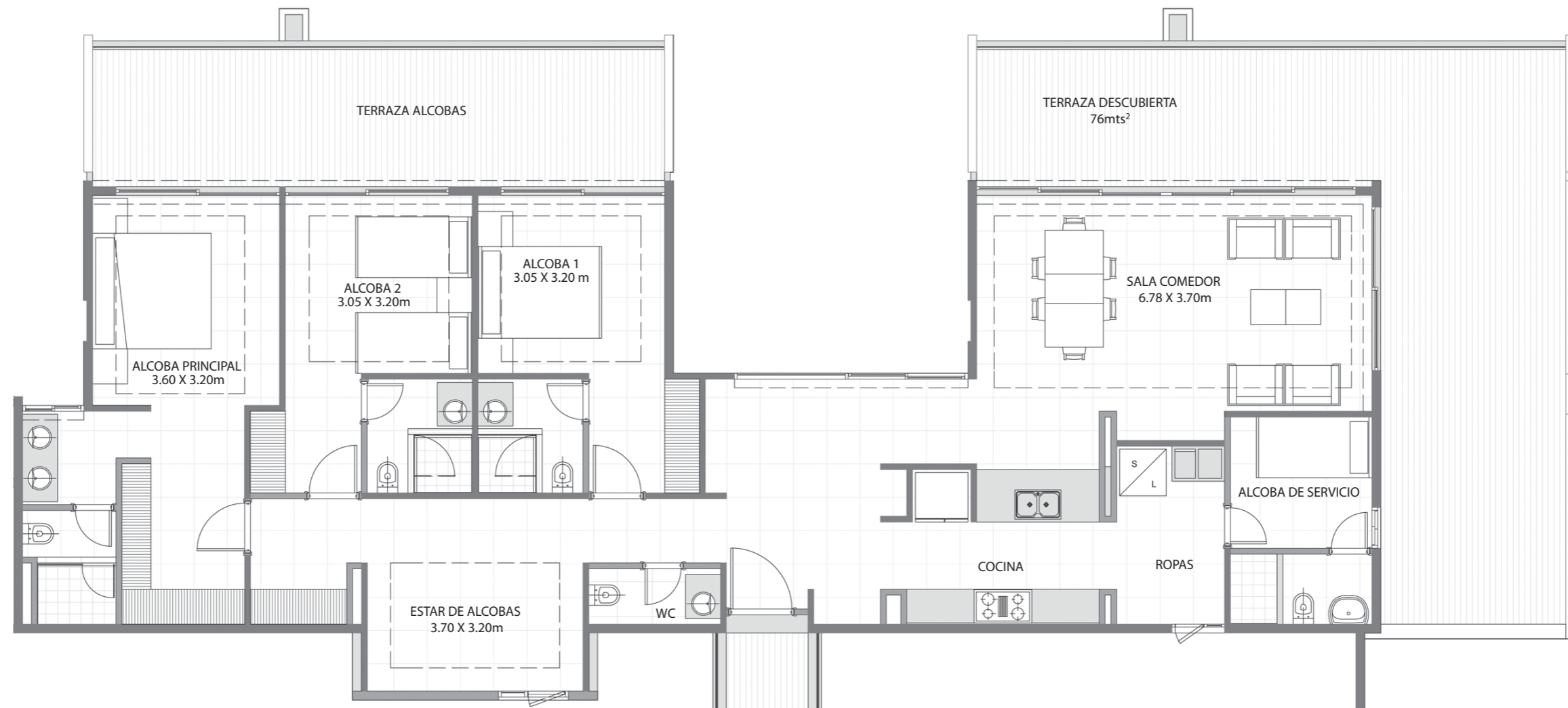
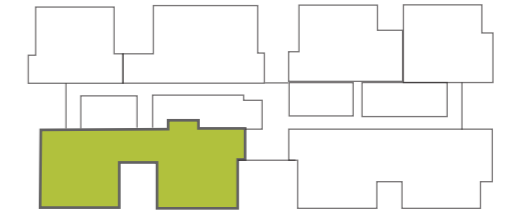

Penthouse I: 237M<sup>2</sup>



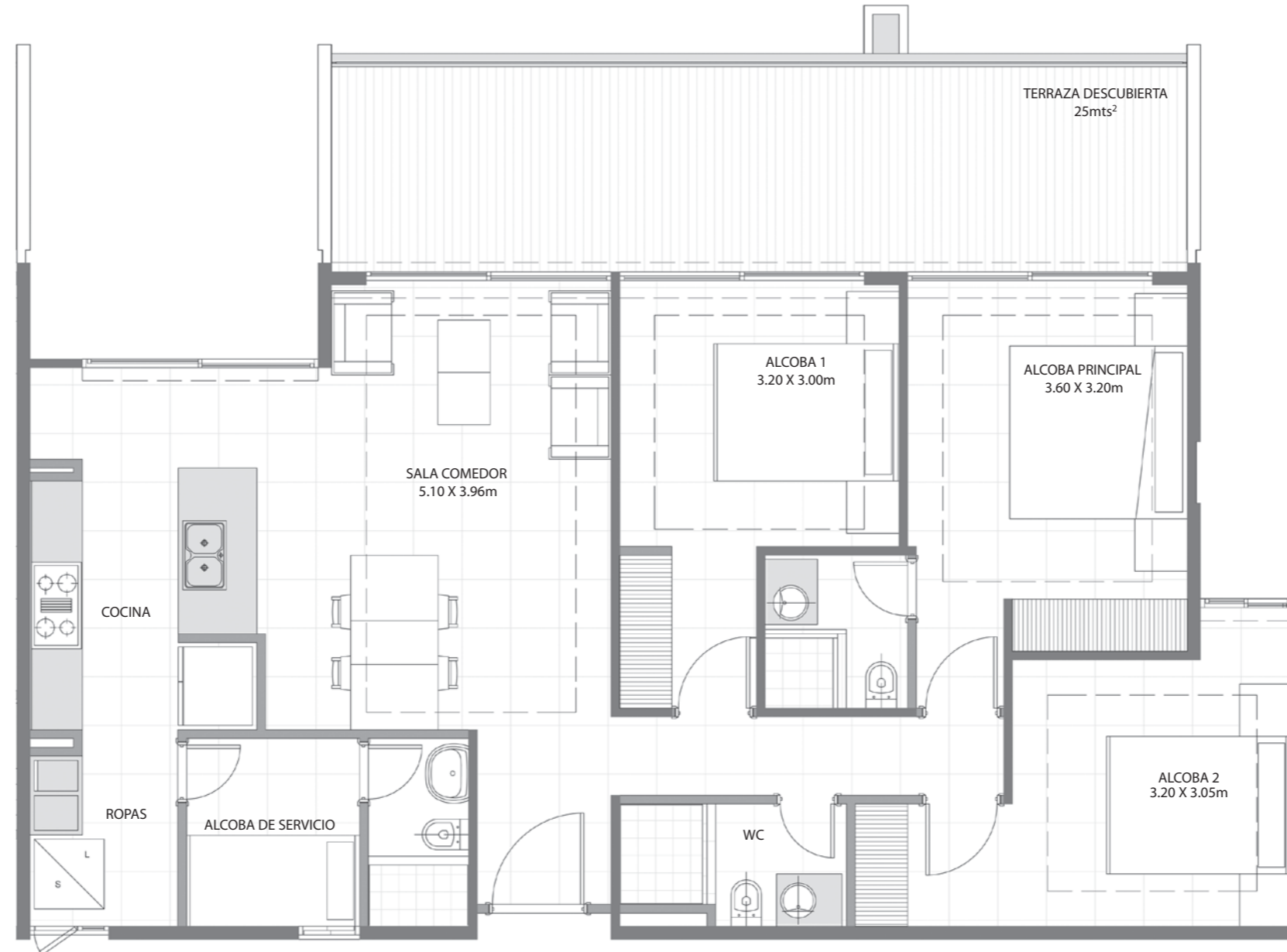
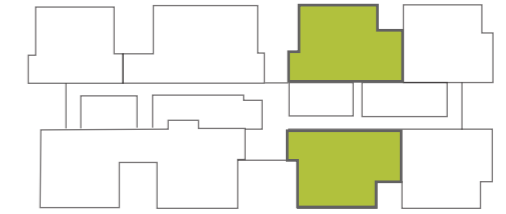

Penthouse 2: 128M<sup>2</sup>

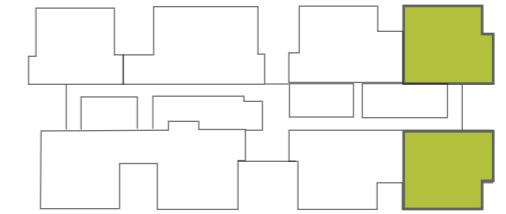
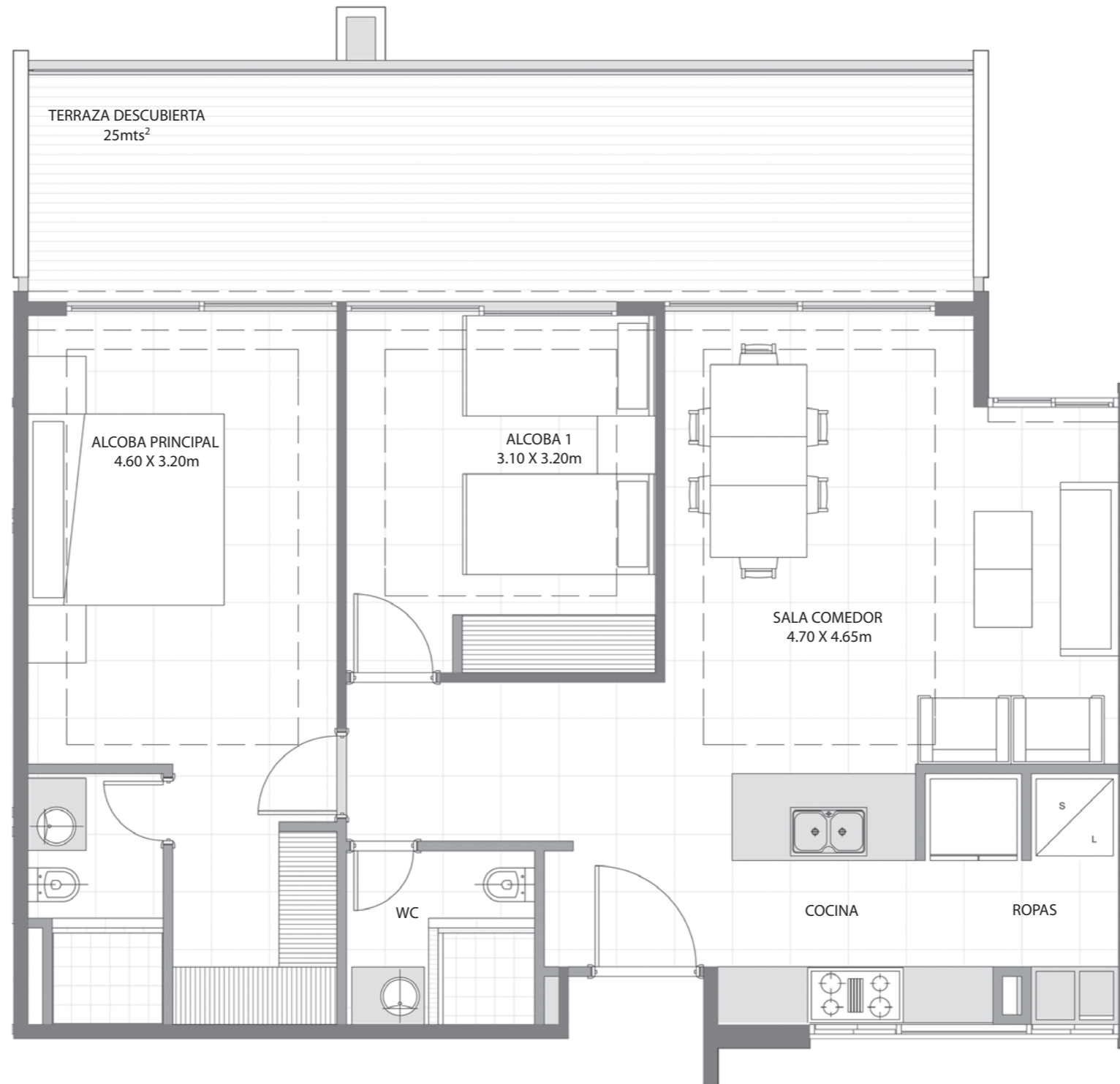

Penthouse 3: 111M<sup>2</sup>

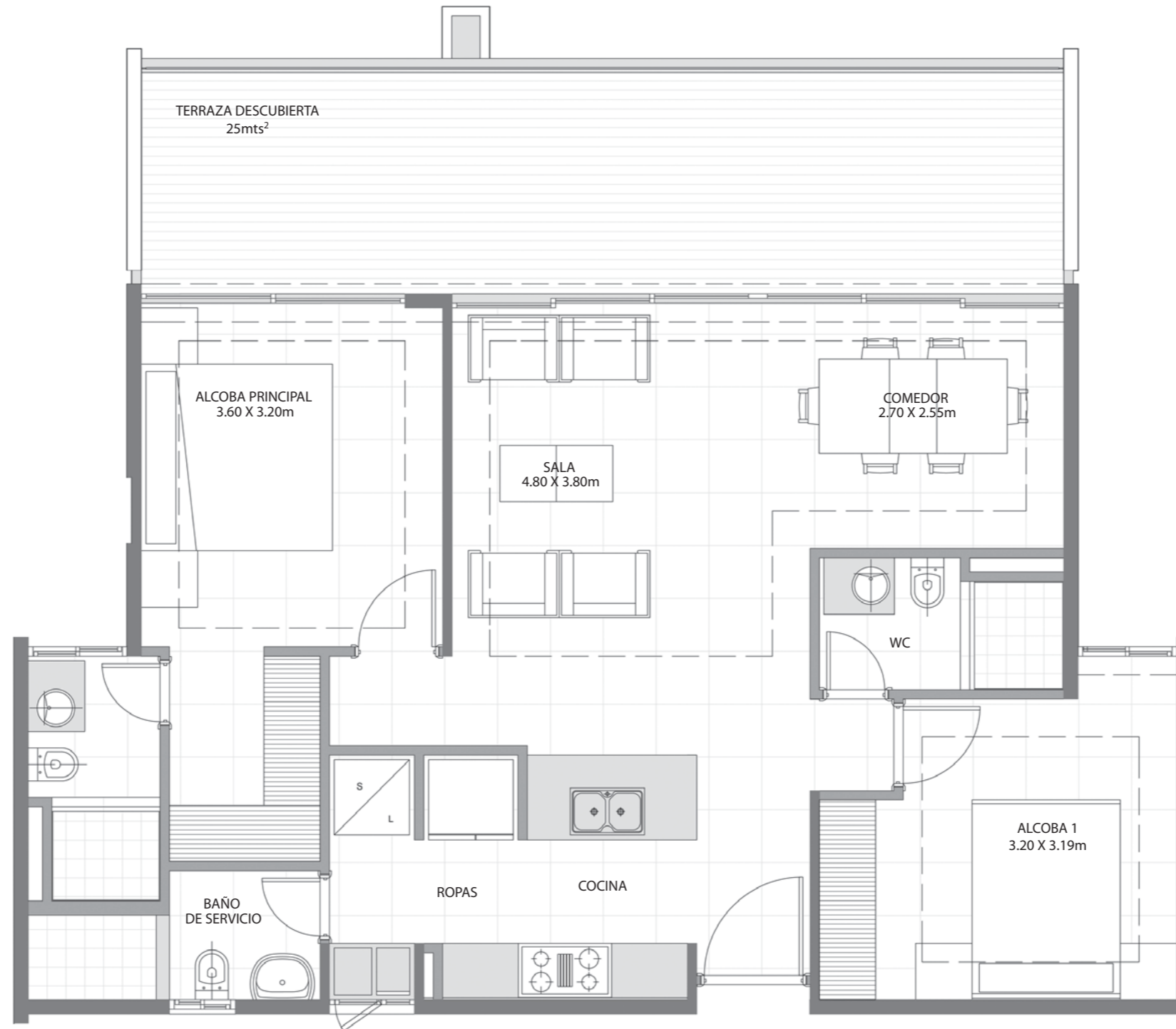
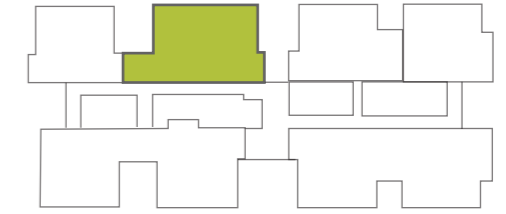

Penthouse 4: 110M<sup>2</sup>

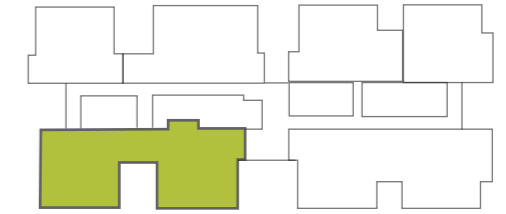

Penthouse 5: 154M<sup>2</sup>



# *Barajas*

C O N S T R U C T O R A

CARTAGENA, Bocagrande. Cra 3 No. 6 A - 100 Torre Empresarial Protección Local No. 3

**Tels: (57 – 5) 6552609 • Cels: 3135006666, 3145459524 - Teléfono USA: 7864721908**

e-mail: [ventas@barajas.com.co](mailto:ventas@barajas.com.co) • [www.barajas.com.co](http://www.barajas.com.co)